

SERVICE DATA

DESCRIPTION

Model 37-650 is an 8 tube superheterodyne receiver for operation on alternating current. It has three tuning ranges, covering standard broadcast and short-wave frequencies. The chassis is constructed in four basic assembly units, concentrating the R. F., I. F., Audio and Power Circuits in individual units.

The circuit includes the Philco Foreign Tuning System—controlled by the range switch—providing maximum sensitivity and noise reduction, when used with the Philco High Efficiency Aerial; one stage of radio frequency amplification before the Detector-Oscillator tube; Automatic Bass Compensation in the Volume Control Circuit; Shadow Tuning; Automatic Volume Control, and a Push-Pull Pentode Output Circuit.

AERIAL CONNECTIONS

The red and black leads of the High-Efficiency Aerial "transmission line" are connected to terminals 1 and 2 respectively, of the terminal panel provided at the rear of the chassis. Connect the jumper on the terminal panel across terminals 3 and 4.

If a temporary aerial is used, the jumper should be across terminals 2 and 3. The aerial connects to terminal 1 and the ground lead to terminal 3. A good ground connection is desirable in all installations.

REPLACING DIAL

To replace the dial, remove the clamp holding the dial to the hub by turning clamp counter-clockwise, using the two holes provided on the clamp for this purpose.

REMOVING MASK ARM & LINK ASSEMBLY

First remove dial, then loosen set screw of dial hub and remove the hub and felt washer from the shaft. Now loosen screws holding indicator bracket and lens assembly, and move bracket forward about 1/2 inch. The assembly may now be removed by loosening set screw of range switch arm, then pull arm off of range switch shaft.

REMOVING SWITCH & COIL ASSEMBLIES OF R. F. UNIT
To replace any part in the switch and coil assemblies of the R. F. Unit, each assembly can be removed separately as follows:

First remove the tuning dial, mask and arm assembly. Remove the center mounting screw on the rear of the R. F. Unit. Then lift the rear of the unit and push forward until the rubber mounting grommets, on each side of the unit, clear the mounting slots. The unit is then lifted far enough from the chassis for removal of the two screws holding the selector switch indexing plate and shaft (front of unit). Then pull shaft straight out from the unit. Also, remove the volume control shaft by releasing the retaining clip, inside the chassis, from the shaft.

IMPORTANT—When selector switch shaft is replaced, care should be taken to have all wafers rotors in the same position, so that the key on the switch shaft will slide freely into the notched hole in each wafers rotor. NEVER force shaft into rotors.

Servicing Stages—It is necessary to unsolder some connecting leads in order to release the stage for servicing. If all the following connections are unfastened the stage will be entirely released. Ordinarily only one or two leads need be loosened in order to change coils, replace coupling condensers, or replace switch sections.

Antenna Stage Assembly—Rear Section of Unit

A. Remove screw holding shield plate to the unit base. This screw is located in the right hand corner of the shield plate, facing rear underside of the chassis.

B. Unsolder the wires at the I. F. and Aerial terminal panels which connect to the range switch, also wires from tuning condenser housing to tubular condenser (6); tuning condenser stator plate to selector switch contact (B3), and ground lead from assembly shield to unit frame. After disconnecting these wires assembly may be removed.

R. F. Stage Assembly—Middle Section

A. Remove screw (right side of assembly) holding shield plate to unit base.

B. Unsolder the two wires connecting the I. F. Unit to range switch contacts (C3) and (D12); also wires connecting tuning condenser housing to tubular condenser (6) and stator plates to selector

switch contact (D3); selector switch contact (D2) to the grid of the 6A8G tube, and ground lead from shield to unit frame. Remove assembly from the unit.

Oscillator Stage Assembly—Front Section

A. The oscillator assembly may be removed by unscrewing the four screws holding shield to R. F. base. These screws are located on each side of the R. F. Unit.

B. Unsolder the wires connecting range switch contacts (E2) and (F2) to the 6A8G socket; tuning condenser stator plates to range switch contact (F3); mica condenser (10) to the tuning condenser housing; range switch to resistor (8) and (9), and ground lead to I. F. Unit. With these leads disconnect unit may be removed.

Replace the units by following the above procedure in the reverse order.

Electrical Specifications

Power Supply:	Voltage	Frequency Cycles	Consumption
	115	50-60	110 watts
	115	25-40	110 watts

Intermediate Frequency: 470 K. C.

Output: Undistorted 7 watts.

Philco Tubes: 6K7G—R. F. Amplifier; 6A8G—Oscillator and first detector; 6K7G—I. F. Amplifier; 6J5G—2nd Detector, A. V. C.; 6K5G—1st Audio; 2-6F6G—Output; 5Y4G—Rectifier.

Tuning Ranges: Range 1—530 to 1720 K. C.; Range 2—5.7 to 11.6 M. C.; Range 3—11.5 to 18.2 M. C.

Speakers: X Cabinet—H-26; B Cabinet—K-35.

POWER TRANSFORMER DATA

Schematic Lead No.	A. C. Volts	Current	Circuit	Color	Resistance
1-2	120	—	Pri.	White	2.0 ohm
3-4	5.	2.0A	Rect. Fil.	Blue	Less than 0.1 ohm
5-7	700	135 MA	High Volt. Sec.	Yellow	55 ohms 60 ohms
6	—	—	Center Tap 5-7	Yellow Green tr.	—
8-9	6.7	3.3 A	Fil.	Black	Less than 0.1 ohm

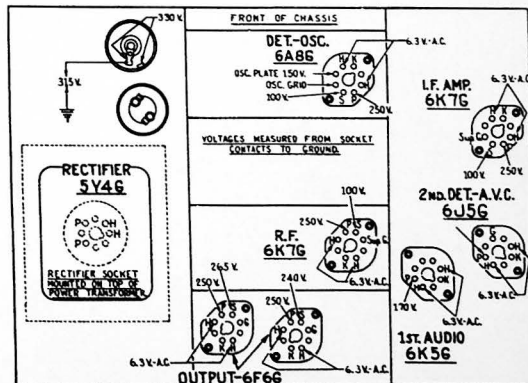
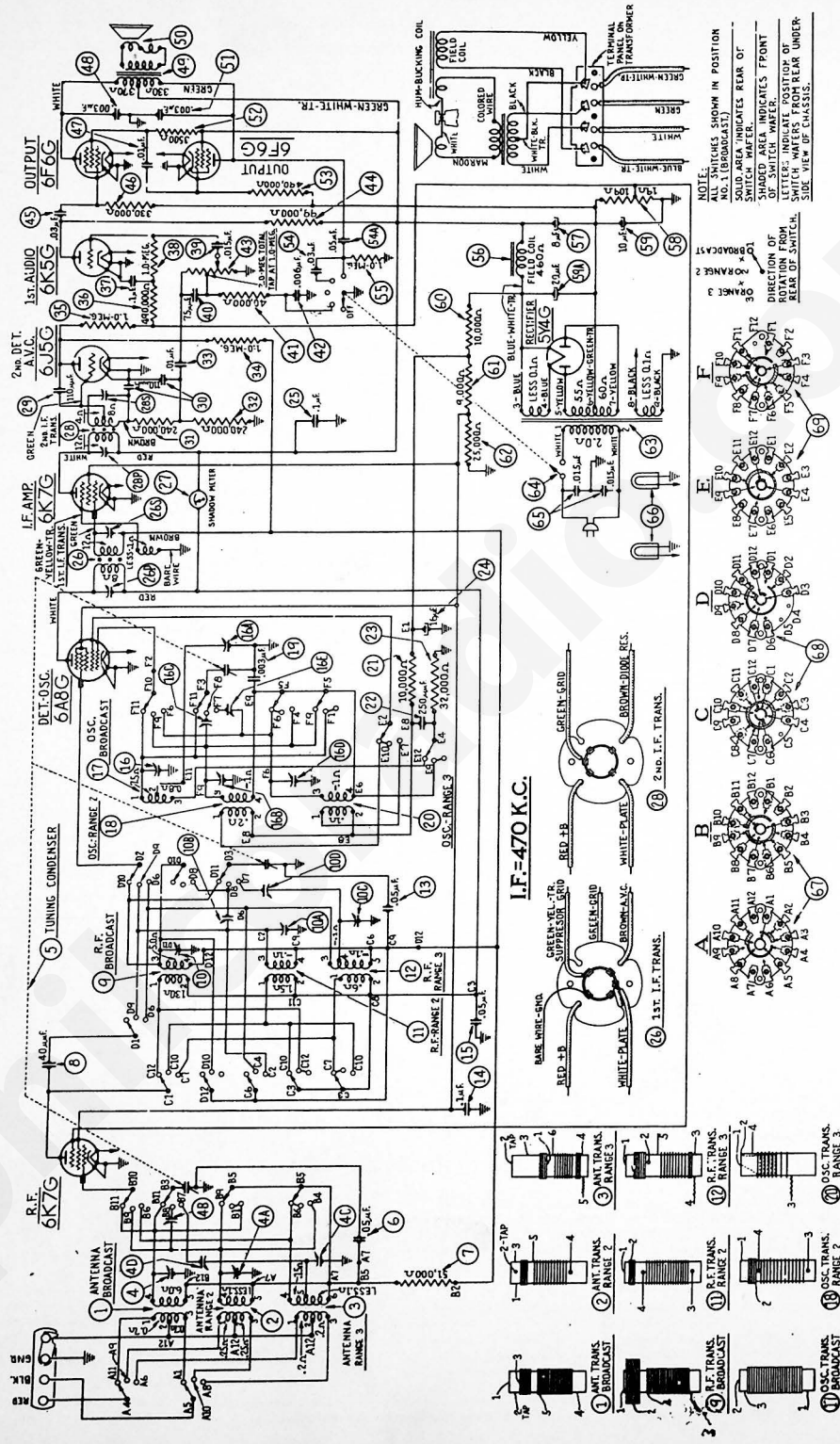

Fig. 1—Socket Voltages—Underside of Chassis View

The voltages indicated by arrows were measured with a Philco #25 Circuit Tester which contains a voltmeter having a resistance of 1000 ohms per volt. Volume Control at minimum, range switch in broadcast position, line voltage 115 A. C.



**Fig. 2—Schematic Diagram
 Model 37-650**

NOTE:
 NO. 1 INDICATES SHOWN IN POSITION
 AND 2 INDICATES SHOWN REAR OF
 SOLID AREA INDICATES FRONT
 SHADDED AREA INDICATES FRONT
 SWITCH WAFER.
 DIRECTION OF
 ROTATION FROM
 LETTERS INDICATE POSITION OF
 SWITCH WAFERS FROM REAR UNDER
 SIDE VIEW OF CHASSIS.

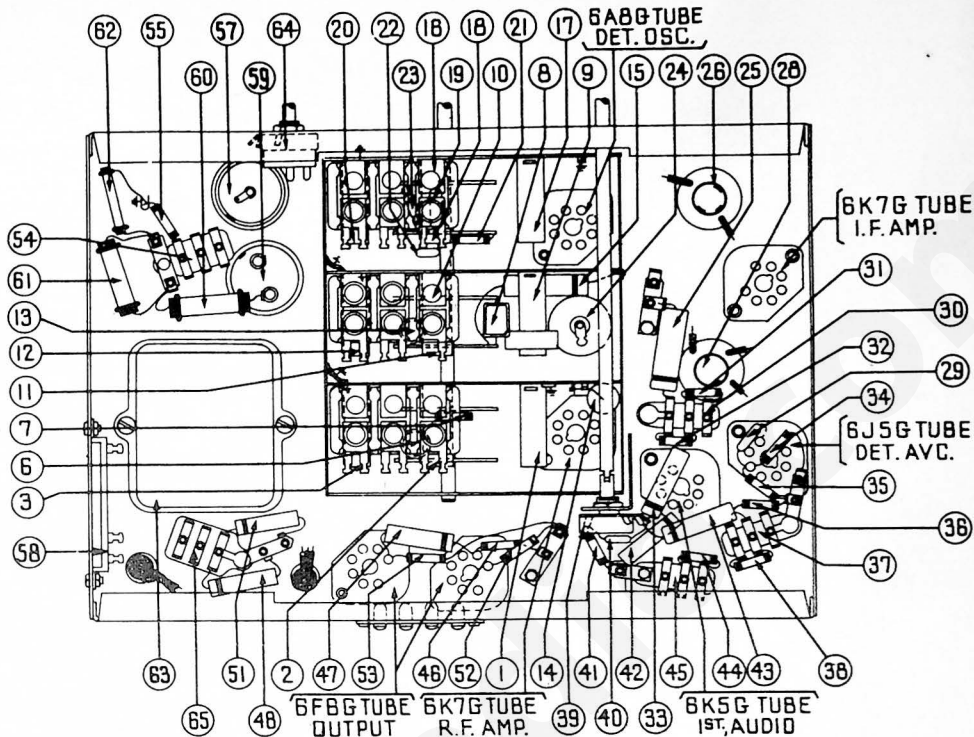

Fig. 3—Base View

Replacement Parts—Model 37-650

Schem. No.	Description	Part No.	Price List	Schem. No.	Description	Part No.	Price List	Schem. No.	Description	Part No.	Price List
1	Ant. Transformer (Broadcast)	32-2108	\$0.80	49	Output Transformer K35-H26	32-7634	\$1.50		Tube Shield	28-2726	
2	Ant. Transformer	32-2150	.80	50	Cone and Voice Coil K35	36-3174	.80		Terminal Panel Assembly I. F.	38-6306	\$0.10
3	Ant. Transformer (S. W.)	32-2176	.80	51	Cone and Voice Coil H26	02625	1.20		Terminal Panel Antenna	38-7714	.15
4	Compensator Ant. (Five sections)	31-6104		51	Condenser (.003 mfd. tubular)	30-4469			Grommet Mtg. R. F. Unit	27-4317	.04
5	Tuning Condenser	31-1855	4.50	52	Resistor (3500 ohms, 1/2 watt)	33-235339	.20		Sleeve Mtg. R. F. Unit	28-2257	.01
6	Condenser (.05 mfd. tubular)	30-4020	.20	53	Resistor (490000 ohms, 1/2 watt)	33-449339	.20		Screw Mtg. R. F. Unit	W-729	.45
7	Resistor (51000 ohms, 1/2 watt)	33-351339	.20	54	Condenser (.05 mfd., .03 mfd. bakelite)	3615-YU			Washer Mtg. R. F. Unit	28-3927	.01
8	Condenser (.05 mfd. tubular)	30-4170	.20	55	Resistor (1 megohm, 1/2 watt)	33-510339	.20		Washer Felt R. F. Unit	27-7807	Per C .40
8	Condenser (40 mmfd. mica)	30-1076	.20	56	Field Coil K35-H26	36-3687			Grommet Mtg. Tuning Condenser	27-4325	.02
9	R. F. Transformer (Broadcast)	32-2105	.75	57	Electrolytic Condenser 8.0 mfd.	30-2924	1.10		Shadowmeter Lamp Shield	28-2917	.02
10	Compensator (R. F.) (Five sections)	31-6110		58	Bias Resistor	33-3280			Mtg. Plate R. F. Transformer	28-3806	.02
11	R. F. Transformer	32-2151	.60	59	Electrolytic Condenser (10, 20 mfd.)	30-2163			Mtg. Spacer R. F. Transformer	W-1635	Per C .30
12	R. F. Transformer (S. W.)	32-2176	.70	60	Resistor (10000 ohms, 2 watt)	33-310539			Shaft Volume Control	35-6060	.12
13	Condenser (.05 mfd. tubular)	30-4020	.20	61	Resistor (9000 ohms, 2 watt)	33-290539	.30		Clip Retaining	28-4394	.03
14	Condenser (1 mfd. tubular)	30-4170	.25	62	Resistor (25000 ohms, 1 watt)	33-325339	.20		Terminal Cover Speaker	36-3672	
15	Condenser (.03 mfd. tubular)	30-4123	.20	63	Power Transformer 115 V., 50-60 cycles	32-7606			Cord A. C.	I-2183	.40
16	Compensator Osc. (Six sections)	31-6111		64	Tone Control & A. C. Switch	42-1184			Insulator Electrolytic Condenser	27-7194	.01
17	Osc. Transformer (Broadcast)	32-2120	.65	65	Condenser (.015 mfd. double bakelite)	3763-DG	.40		I. F. Shield	38-7984	
18	Osc. Transformer	32-2132	.75	66	Pilot Lamp	34-2039	.15		Shadowmeter Mtg. Spring	28-8623	Per C .70
19	Condenser (.003 mfd. mica)	30-1028	.45	67	Range Switch Ant.	42-1189	1.25		Knob Tuning Vernier	27-4331	.10
20	Osc. Transformer (S. W.)	32-2182	.70	68	Range Switch R. F.	42-1190	1.25		Knob Tone Volume	27-4332	.10
21	Resistor (10000 ohms, 1/2 watt)	33-310339	.20	69	Range Switch Osc.	42-1191	1.25		Knob Range Switch	27-4326	.10
22	Condenser (250 mmfd. mica)	30-1032	.25		Selector Switch Indexing Plate & Shaft	42-1192	.50		Terminal Panel Speaker	36-3672	
23	Resistor (32000 ohms, 1/2 watt)	33-325339	.20		Dial	27-5248	.40				
24	Electrolytic Condenser (16 mfd.)	30-2118	1.65		Dial Hub	28-7187	.12				
25	Condenser (.1 mfd. tubular)	30-4170	.25		Dial Clamp	28-2837	.10				
27	Shadow meter	45-2189	2.50		Set Screw	W-1641	.02				
28	2nd I. F. Transformer & Compensators	32-2171			Retaining Washer	4436	Per C 1.50				
29	Condenser (110 mmfd. mica)	30-1031	.20		Gear (Dial)	28-7185	1.10				
30	Condenser (110 mmfd. double bakelite)	8035-DG	.25		Gear Drive	31-8864	.25				
31	Resistor (240000 ohms, 1/2 watt)	33-424339	.20		Thrust Spring	28-8611	.01				
32	Resistor (240000 ohms, 1/2 watt)	33-424339	.20		Thrust Washer	28-3976	Per C .30				
33	Condenser (.01 mfd. tubular)	30-4124	.20		C Washer	28-3904	.01				
34	Resistor (1 megohm, 1/2 watt)	33-510339	.20		Scale Guard	27-8324	.40				
35	Resistor (1 megohm, 1/2 watt)	33-510339	.20		Indicator Bkkt. & Lens Assembly	38-7912	.30				
36	Resistor (190000 ohms, 1/2 watt)	33-449339	.20		Pilot Lamp	34-2039	.15				
37	Condenser (1 mfd. bakelite)	4889-SG	.35		Pilot Lamp Assembly	38-7706	.35				
38	Resistor (1 megohm, 1/2 watt)	33-510339	.20		Mask	27-8198	.20				
39	Volume Control	33-5158	1.00		Mask Arms & Link Assembly	31-1866	.35				
40	Condenser (.75 mmfd. mica)	30-1053	.20		Mask Guide	38-7844	.25				
41	Resistor (40000 ohms, 1/2 watt)	33-340339	.20		Mask Washer	27-8318	Per C .50				
42	Condenser (.006 mfd. tubular)	30-1125	.20		Socket 8 prong	27-6058	.11				
43	Condenser (.015 mfd. tubular)	30-4358	.20		Socket 7 prong	27-6057	.11				
44	Resistor (99000, 1/2 watt)	33-509339	.20		Socket, Rect. Rect.	27-6052	.08				
44	Condenser (.03 mfd. bakelite)	8318-SU	.35		Tube Shield Base	28-3898					
46	Resistor (380000 ohms, 1/2 watt)	33-433339	.20								
47	Condenser (.01 mfd. tubular)	30-1169	.20								
48	Condenser (.003 mfd. tubular)	30-4469	.20								

Figures in black type indicate circled figures in Base View.

Price Subject to Change without Notice

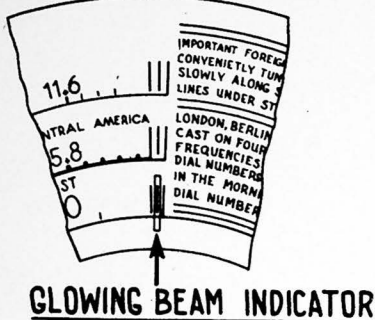

Fig. 4—Dial Calibration

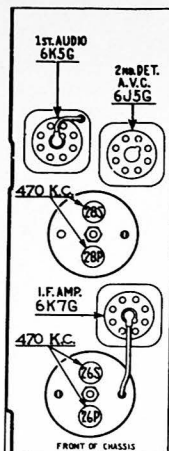

Fig. 5—I. F. Compensators—Top of Chassis

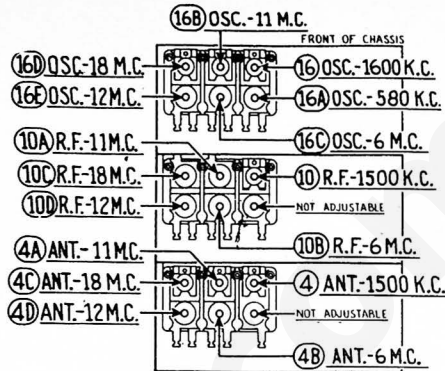

Fig. 6—R. F. Compensators—Underside of Chassis

Alignment of Compensators

The accurate adjustment of the various compensating condensers is vital to the proper functioning of this receiver. There are four compensating condensers in the I. F. Circuit, six in the Oscillator Circuit, five in the R. F. Amplifier Circuit and five in the Antenna Circuit. Incorrect adjustment will cause loss of sensitivity, unsatisfactory tone, and poor selectivity.

To accurately adjust this receiver, precision test equipment is necessary. A signal generator such as the PHILCO MODEL 088 SIGNAL GENERATOR, covering from 110 to 20,000 K. C. is recommended to adjust the compensators at the various frequencies specified. A visual indication of the receiver output is also necessary to obtain correct adjustment of the compensators. PHILCO MODEL 025 CIRCUIT TESTER contains a sensitive output meter and is recommended for these adjustments.

Philco Fibre Handle Screw-driver No. 27-7059 completes the necessary equipment for these adjustments. The locations of the various compensators are shown in Figs. 5 and 6.

The following procedure must be observed in adjusting the compensators:—

SHADOWMETER ADJUSTMENT

1. Remove the aerial and allow tubes to warm up. Then adjust shadowmeter as follows: Move the coil backward and forward until opposite edges of the shadow are $\frac{1}{4}$ of an inch from each end of shadow screen, measuring along bottom edge. Adjustment of the shadowmeter light bracket may be necessary for perfect centering.

2. Remove the (5Y4G) rectifier tube from its socket and rotate coil until shadow reaches minimum width. This width is not to exceed $\frac{1}{16}$ ".

3. Replace the (5Y4G) rectifier tube. Shadow must not widen to more than $\frac{1}{8}$ " or less than $\frac{1}{16}$ " from each side of screen. If these limits are not obtained readjust the shadowmeter as given in paragraphs 1 and 2 until they are reached.

OUTPUT METER—The 025 Output Meter is connected to the plate and cathode terminals of one of the (6F6G) tubes. Adjust the meter to use the (0-30) volt scale.

DIAL CALIBRATION—Rotate the tuning condenser control to the extreme counter-clockwise position (maximum capacity). Loosen the screw of dial hub, then turn dial until the glowing indicator is centered on the second index line of dial scale (see Fig. 4). Then tighten the dial hub set screw in this position.

INTERMEDIATE FREQUENCY CIRCUIT

Frequency 470 K. C.

1. Turn volume control to maximum volume position. Connect the 088 Signal Generator output through a .1 mfd. condenser, to the control grid of the 6A8G tube and the ground connection of the output lead to the chassis.

2. Set the range switch in position No. 1 (Broadcast), then rotate the tuning condenser of the receiver to the maximum capacity position (counter-clockwise) and adjust the signal generator for 470 K. C.

3. Adjust compensators (28S) 2nd I. F. Sec., (28P) 2nd I. F. Pri., (26S) 1st I. F. Sec. and (26P) 1st I. F. Pri. for maximum reading on the output meter.

RADIO FREQUENCY CIRCUIT

Tuning Range—7.3 to 18.0 M. C.

1. Remove the signal generator output lead from the grid of the 6A8G tube and connect it through the .1 mfd. condenser to terminal No. 1 on aerial input panel and the generator ground lead to terminal No. 3, rear of chassis. Terminals 2 and 3 must be connected with the shorting link provided on the panel during these adjustments.

2. Set the range switch in position No. 3. Turn the receiver and signal generator dials to 18 M. C. Now adjust compensator (16D) by turning the screw (clock-

wise) to the maximum capacity position. Then slowly turn it counter-clockwise until a set peak is obtained on the output meter. The first peak from maximum capacity is the image signal and must not be used. NOTE: In some cases only one peak will be found, therefore, tune the compensator to this peak. If the above procedure is correctly performed, the image signal will be found at 17,060 M. C., by advancing signal generator input and turning receiver dial to this frequency mark on the dial.

3. The antenna and R. F. compensators (4C) and (10C) are now adjusted by connecting a variable condenser of approximately 350 mmfd.,—having a good vernier drive—across the oscillator compensator (16D) contact (third contact from left side of receiver facing rear underside view of chassis) and ground. Leaving the signal generator and receiver dials at 18 M. C., tune the added condenser until the second harmonic of the receiver oscillator beats against the signal from the generator, thereby giving an indication on the output meter. It may be necessary to increase the signal generator output to obtain a signal of sufficient strength for reading on the output meter. The antenna and R. F. compensators (4C) and (10C) should then be adjusted for maximum output. Then remove external condenser and readjust compensator (16D) as given in paragraph 2 above.

4. Turn signal generator and receiver dials to 12 M. C. and adjust compensators (16E), (10D), (4D) for maximum output.

5. Now turn signal generator and receiver dials to 18 M. C. and readjust compensators (16D), (10C) and (4C) as given in Paragraphs 2 and 3 above.

Tuning Range—5.7 to 11.6

1. Set range switch in position No. 2. Rotate signal generator and receiver dials to 11 M. C. Compensator (16B) is now adjusted as given in Paragraph 2, under tuning range 7.3 to 18 M. C. above. Check image signal on the 10.08 dial mark. The only difference in the two procedures is the frequency used.

2. Turn the signal generator to 11 M. C. Then connect a 350 mmfd. variable condenser from the oscillator compensator (16B) contact (third contact from left side of the receiver, facing rear underside view of chassis) and ground. Tune the added condenser, as given in Paragraph 3 under tuning range 7.3 to 18 M. C. Now adjust compensators (10A) and (4A) for maximum output. The only difference in the two procedures is in the connection of the variable condenser and the frequency used.

3. Readjust compensator (16B) as given in Paragraph 1 for maximum output.

4. Turn signal generator and receiver dials to 6 M. C. and adjust compensators (16C), (10B) and (4B) for maximum output.

5. After the 6 M. C. end of scale is adjusted, the high frequency end is readjusted as given in Paragraphs 1, 2 and 3 above.

Tuning Range—530 to 1720 K. C.

1. Turn signal generator and receiver dials to 1600 K. C.—If signal generator scale is not calibrated for 1600 K. C. the dial of the generator may be rotated to 800 K. C. and the second harmonic of this frequency (1600 K. C.) may be used for following adjustments. Compensators (16), (10) and (4) are now adjusted for maximum output.

2. Turn signal generator and receiver dials to 580 K. C. and adjust compensator (16A) for maximum output. This is accomplished as follows:

First tune compensator (16A) for maximum output. Then vary the tuning condenser for maximum output about the 580 K. C. scale mark. Now return compensator (16A), and again vary the tuning condenser back and forth about 580 K. C. for maximum output. This operation of first tuning the compensator, then the tuning condenser is continued until maximum output is obtained on or about the 580 K. C. dial mark.

3. Turn signal generator and receiver dials to 1600 K. C. and readjust compensator (16) for maximum output.

4. Now rotate signal generator and receiver dials to 1500 K. C. and adjust compensators (10) and (4) for maximum output.

Use the New

PHILCO

IDENTIFIED

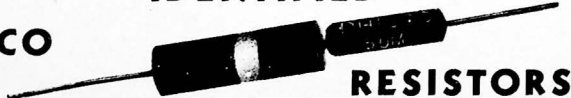

RESISTORS

YOUR DISTRIBUTOR CAN SUPPLY YOU

Save Time
and Trouble
on all
Service Jobs